

Pole Pockets How To:

We measure pole pockets as follows.
A 3" Pole Pocket would be as follows

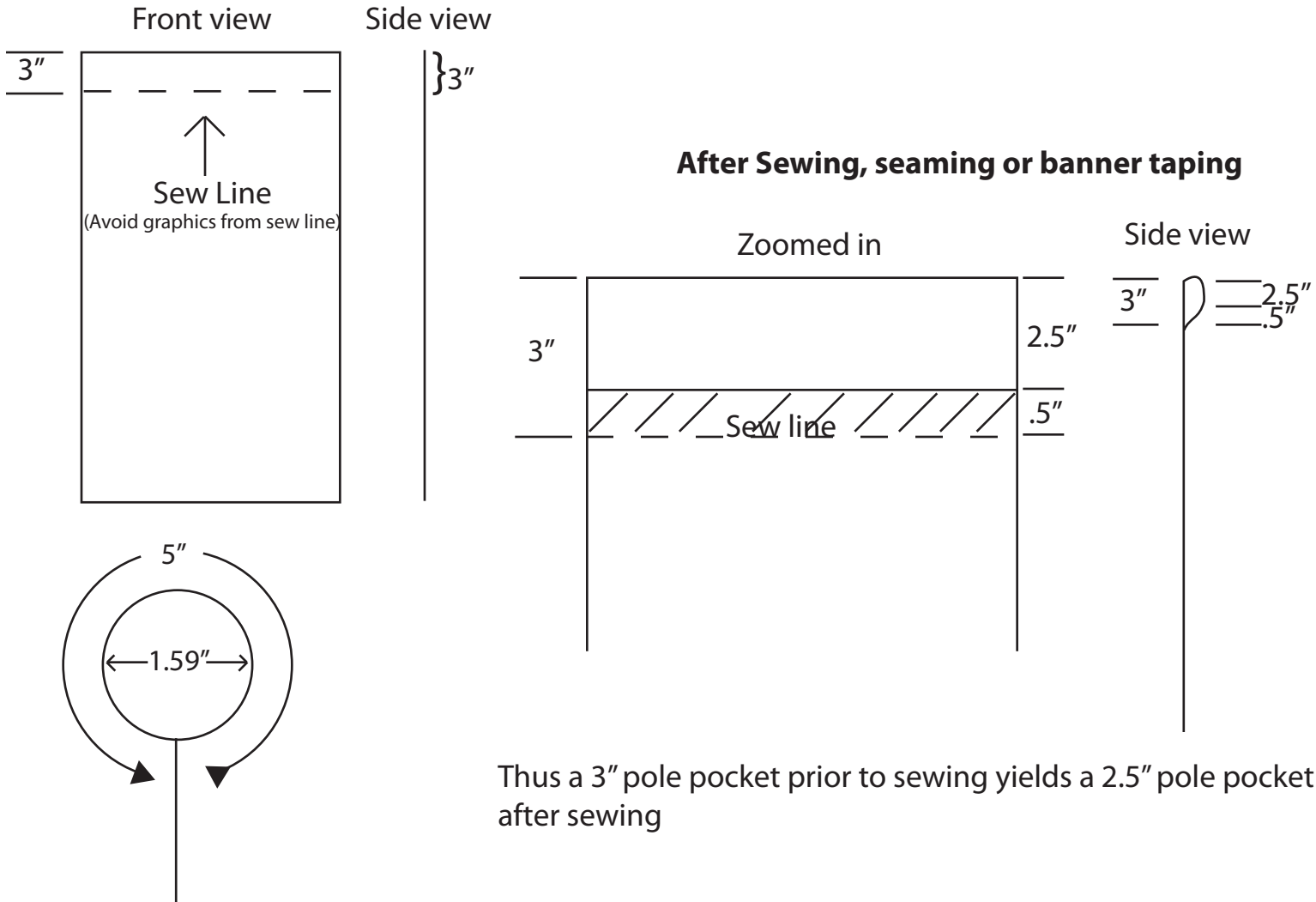

This 2.5" Pole Pocket after sewing creates a pocket with a 5" circumference

This translates to a pocket which will hold a pole with a diameter of 1.59" ($5 / 3.14 = 1.59$)

As a general following pole pocket sizes

Product	Pole pocket prior to sewing	Pole pocket after sewing	Circumference	Max pole diameter
Excel/ Round Hanging banner	3"	2.5"	5"	1.59"
BN-4/BN-5 JN4/ JN5 Square, Tri, and hanging banners	3.5"	3.25"	6.5"	2.07"
	4"	3.5"	7"	2.23"
	5"	4.5"	9"	2.86"